

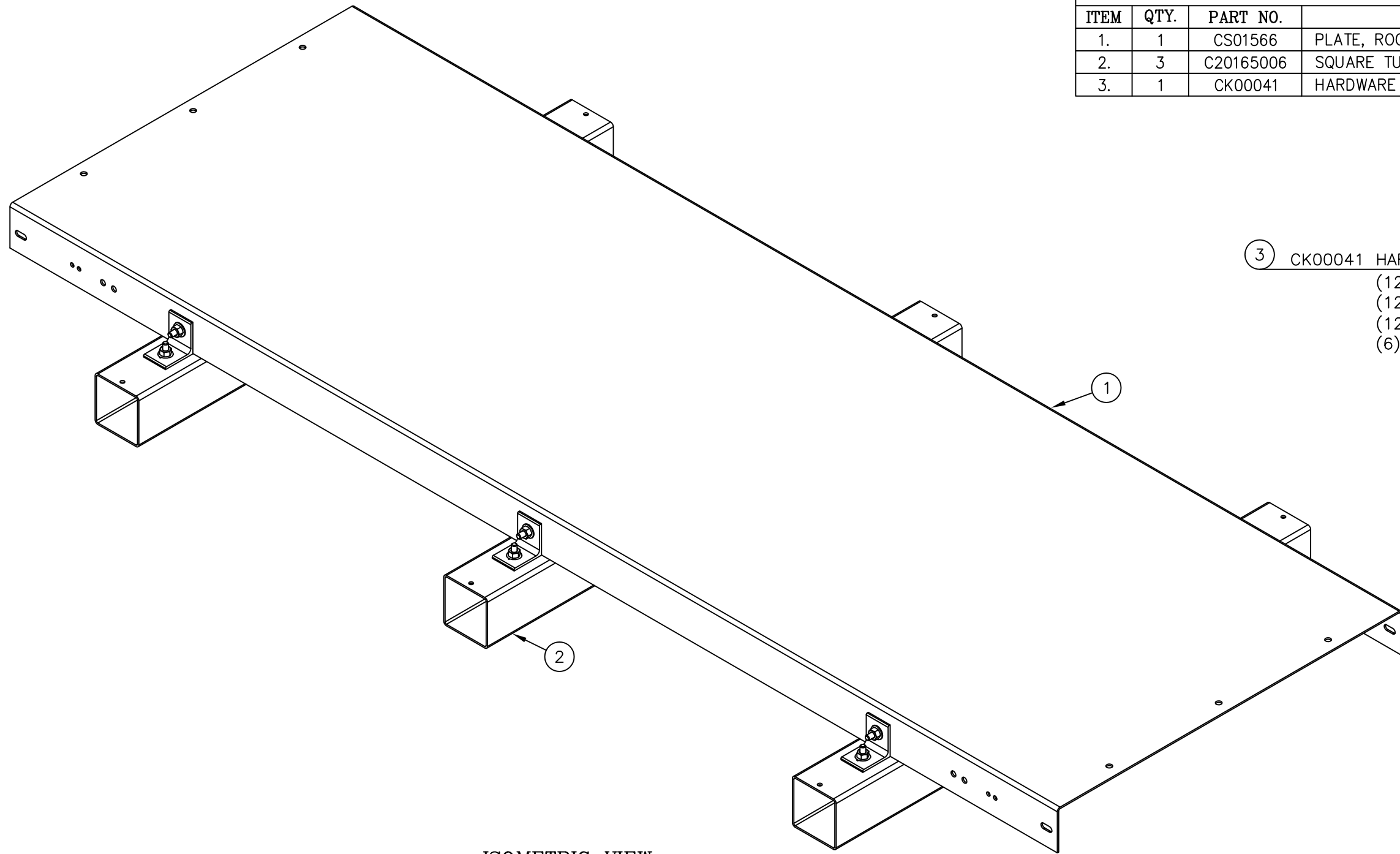

### C20161003 LIST OF MATERIAL FOR ROOFTOP BRIDGE

ITEM	QTY.	PART NO.	DESCRIPTION	WEIGHT
1.	1	CS01566	PLATE, ROOFTOP BRIDGE COVER	115#
2.	3	C20165006	SQUARE TUBE, ROOFTOP BRIDGE SLEEPER (PVC)	12#
3.	1	CK00041	HARDWARE KIT (SEE BELOW FOR LIST)	5#
			TOTAL WEIGHT	132#



- ③ CK00041 HARDWARE KIT INCLUDES:  
 (12) 3/8"-16 X 1 1/4" BOLT ASSEMBLY GR.5  
 (12) 3/8" FLATWASHER  
 (12) 3/8"-16 NYLON RETAINING NUT  
 (6) CLIP ANGLE (sabre738)

ISOMETRIC VIEW

UNLESS OTHERWISE SPECIFIED ALL DIMENSIONS INCLUDE FINISHES AND ARE IN INCHES		MATERIAL:	
TOLERANCES: FRACTIONS $\pm 1/16"$ ANGLES $\pm 1/2$ DEG. DECIMALS $\pm .010"$		TOLERANCES DO NOT APPLY TO RAW MATERIAL	
1	6/23/10	KLE	EK
REV	DATE	DRW	CHK



**CONFIDENTIAL**  
 This document and the information contained herein is the confidential trade secret property of Sabre Communications Corporation ("Sabre") and must not be reproduced, copied or used, in whole or in part, for any purpose without the prior written consent of Sabre.  
 © 2008 Sabre Communications Corporation. All rights reserved.

12 COAX ROOFTOP BRIDGE (31 1/2" WIDE X 8' LONG)				
DATE	1/14/08	SIZE	B	REV
DRAWN BY	JV/MLC	DRAWING NO.	C20161003	1
CHECKED BY	MC	SCALE	None	PAGE
				1 OF 1